

# Model No.8406 DIAMOND CORE HAMMER DRILL

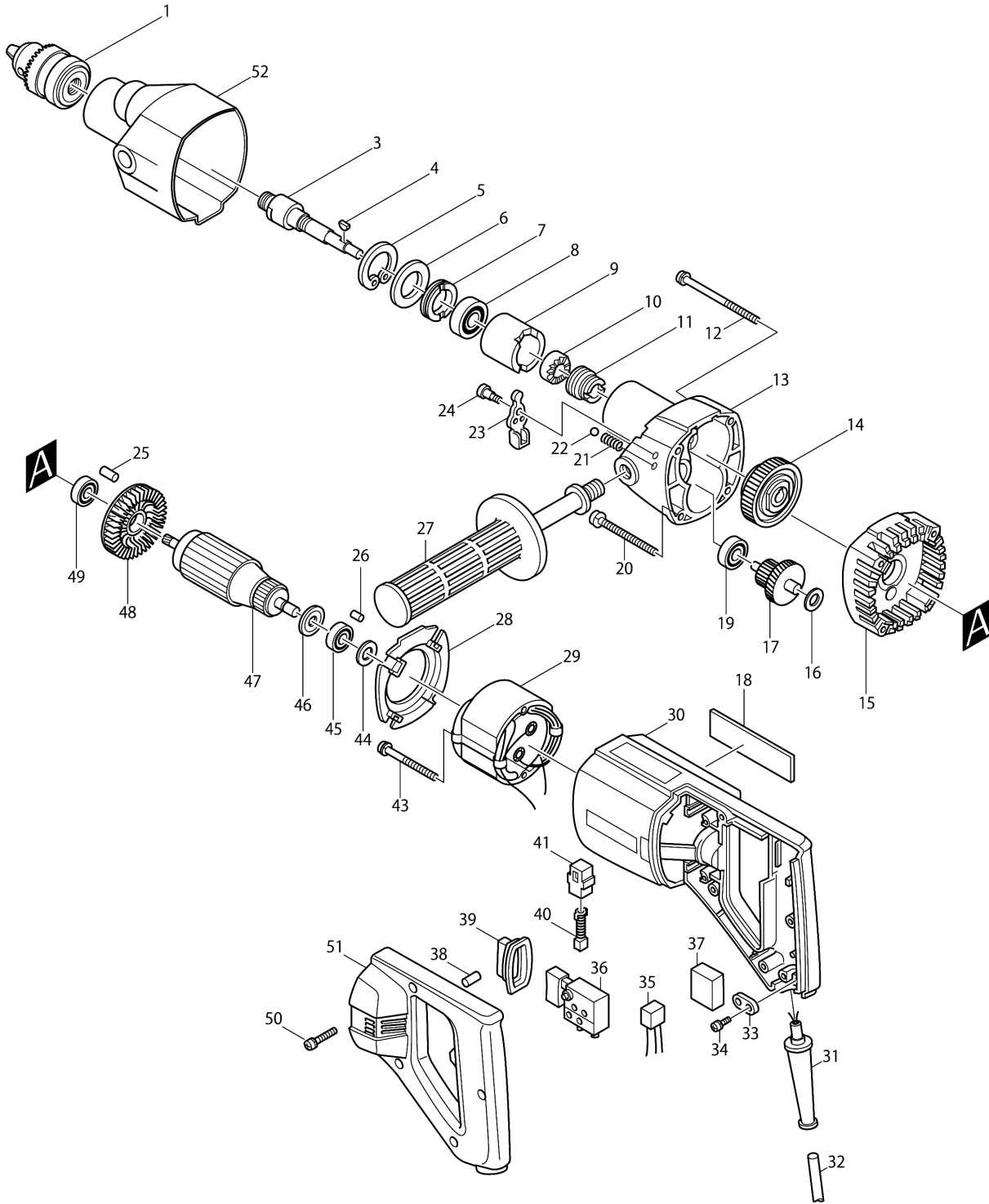

Model No.8406 DIAMOND CORE HAMMER DRILL

Item	Parts No.	Description	I/C	Qty	New/Old	Opt. 1	Opt. 2	Note
001-1	192877-8	DRILL CHUCK S13		1				
003	322340-9	SPINDLE		1	*			
003-1	327250-5	SPINDLE	S	1				
004	254002-0	WOODRUFF KEY 3		1	*			
004-1	254236-5	KEY 3	S	1				
005	962155-8	RETAINING RING R-37		1				
006	423040-5	RUBBER PLATE		1				
007	285819-0	BEARING RETAINER 22-33		1				
008	211201-7	BALL BEARING 6002LLB		1				
009	314101-1	CHANGE RING		1				
010	223069-9	CAM (A) (NEW)		1	*			
010-1	223124-7	CAM A	S	1				
011	223070-4	CAM (B) (NEW)		1	*			
011-1	223125-5	CAM B	S	1				
012	911296-7	PAN HEAD SCREW M5X75		2				
013	159151-7	GEAR HOUSING COMPLETE		1				
C10	256096-1	PIN 5		1				
C20	423030-8	RUBBER PLUG		1				
014	150178-0	TORQUE LIMITER COMPLETE		1				
015	159152-5	GEAR HOUSING COVER COMPLETE		1				
C10	212004-2	NEEDLE BEARING 810		1				
C20	214001-4	PLANE BEARING 8		1				
D10		INC. 25						
016	253139-0	FLAT WASHER 8		1				
017	226095-7	GEAR COMPLETE 19-46		1				
018	856580-2	NAME PLATE 8406		1				
019	211031-6	BALL BEARING 608LLB		1				
020	911271-3	PAN HEAD SCREW M5X50		2				
021	231386-3	COMPRESSION SPRING 3		1				
022	216002-8	STEEL BALL 4.8		1				
023	164512-8	CHANGE LEVER		1	*			
023-1	168272-4	CHANGE LEVER	X	1				
024	251283-7	+ PAN HEAD SCREW M5		1				
025	263002-9	RUBBER PIN 4		1				
026	263014-2	RUBBER PIN 4		1				
027	273472-4	GRIP 32		1				
028	414604-6	BAFFLE PLATE		1				
029C_	522733-2	FIELD ASS'Y 220V		1				
C10	654038-3	INSULATED TERMINAL FT1.25-M4		2	*			
C11	654038-3	INSULATED TERMINAL FT1.25-M4	O	2	*			

Model No.8406 DIAMOND CORE HAMMER DRILL

Item	Parts No.	Description	I/C	Qty	New/Old	Opt. 1	Opt. 2	Note
C12	654038-3	INSULATED TERMINAL FT1.25-M4	O	2	*			
C13	654038-3	INSULATED TERMINAL FT1.25-M4	O	2				
030A_	159382-8	MOTOR HOUSING		1	*			
C10	810685-2	CAUTION LABEL		1	*			
D10		INC. 26			*			
030A1	183523-4	MOTOR HOUSING SET	<	1				
C10	810685-2	CAUTION LABEL		1				
D10		INC. 26						
031-1	682516-3	CORD GUARD 9.3-85		1	*			
031-2	682504-0	CORD GUARD 10-85	O	1				
032F2	665865-3	POWER SUPPLY CORD 1.0-2- 2.5		1				
033A_	687031-2	STRAIN RELIEF		1				
034	911133-5	PAN HEAD SCREW M4X18		2				
035D1	645253-0	NOISE SUPPRESSOR		1				
036A1	651266-1	SWITCH SGE106CV-1		1				
037B_	685700-9	SPONGE SHEET		1				
038	263002-9	RUBBER PIN 4		2				
039-1	421433-0	DUST COVER		1				
040B_	181410-1	CARBON BRUSH CB-106		1	*			
040B1	194976-2	CARBON BRUSH SET CB-106	O	1				
041	643605-9	BRUSH HOLDER		2				
043	911285-2	PAN HEAD SCREW M5X60		2				
044	253192-6	FLAT WASHER 14		1				
045	211031-6	BALL BEARING 608LLB		1				
046	681603-5	INSULATION WASHER		1	*			
046-1	681613-2	INSULATION WASHER	O	1				
047C_	516018-6	ARMATURE ASS'Y 220V		1				
D11		INC. 45,46,48,49						
048	241841-7	FAN 62		1				
049	211031-6	BALL BEARING 608LLB		1				
050	911153-9	PAN HEAD SCREW M4X28		4				
051	159153-3	HANDLE COVER COMPLETE		1				
D10		INC. 38						
052	421454-2	HOUSING COVER		1				
A01-1	763432-9	CHUCK KEY S13		1				
A02	410102-8	KEY HOLDER		1				
A03-1	182622-9	STEEL CARRYING CASE		1	*			
C10	819033-2	MAKITA LABEL		1	*			
A03-2	153603-0	PLASTIC CARRYING CASE COMPLETE	O	1				
C10	417496-2	LATCH		2				

Model No.8406 DIAMOND CORE HAMMER DRILL

Item	Parts No.	Description	I/C	Qty	New/Old	Opt. 1	Opt. 2	Note
C20	417497-0	HANDLE		1				
C30	810632-3	CAUTION LABEL		1				
C40	819143-5	MAKITA LABEL		1				

Please order the parts with part number.

Print Date 25/3/2020