



High Pressure Pneumatic Tools



HIGH PRESSURE



30% LESS
WEIGHT AND VOLUME

Makita High Pressure Pneumatic Tools

CONCEPT

Weight and volume of tool is much less than normal pneumatic tool by using high pressure air.

MERITS

Easy handling. Easy to drive nails upwards. Less fatigue.



Air Compressor AC310H

Applicable for high pressure air nailers and normal pressure air nailers.

- Low noise.
- Two outlets for high pressure air.
- Two outlets for normal pressure air.
- Bumpers for easier carrying.

Compact tank — much compacter than normal pressure compressor because of accommodating high pressure air.

Max. pressure	2.8MPa (410 PSI)
Output power	2.5HP
Tank	6.2L (1.6 gal)
Performance	90L/min
Dimensions (L x W x H)	476 x 507 x 375mm (18-3/4" x 20" x 14-3/4")
Net weight	36kg (79.4lbs)



Construction Coil Nailer

Body bumper protects the workpiece from scratches/ damages.

Rubberized soft grip provides more control and comfort.

Dial for driving depth adjustment

Change lever for selecting the firing mode

Hook attachable to either side



Nose-Piece
with Sure-Grip Spikes
Prevents Slipping.
(except AN450H)

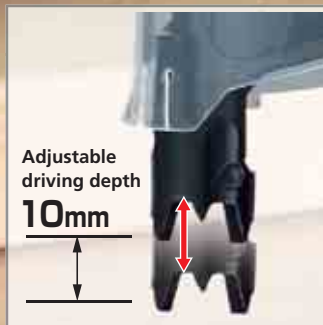

Driving depth
can be adjusted
in 10mm(AN911H, AN711H)
in 6mm(AN610H, AN620H, AN510H)



Easy Load Magazine
Coil support plate in magazine
is ejected automatically when
opening a latch.
It makes an operator
comfortable in loading nails.



Exhaust port
designed to direct exhaust air
away from operator.

Construction Coil Nailers AN911H, AN711H, AN620H, AN610H, AN510H

Very compact and lightweight by using high pressure air



AN911H



AN620H



(AN510H, AN711H, AN911H)



	90mm AN911H	75mm AN711H	65mm AN620H	65mm AN610H	50mm AN510H
	Framing, Sheathing, Steel (3.2mm)		Framing, Sheathing Interior, Steel (2.3mm)	Shingles, Sheathing Interior, Steel (2.3mm)	Shingles, Sheathing Interior, Floor
Capacity	Wire collated nail: 45 - 90mm (1-3/4" - 3-1/2") Sheet collated nail: 45 - 65mm (1-3/4" - 2-1/2")	Wire collated nail: 45 - 75mm (1-3/4" - 3") Sheet collated nail: 38 - 65mm(1-1/2" - 2-1/2")	Wire collated nail: 45 - 65mm(1-3/4" - 2-1/2") Sheet collated nail: 38 - 65mm(1-1/2" - 2-1/2")	Wire collated nail: 32 - 65mm (1-1/4" - 2-1/2") Sheet collated nail: 32 - 65mm (1-1/4" - 2-1/2")	Wire collated nail: 27 - 50mm (1-1/16" - 2") Sheet collated nail: 25 - 50mm (1" - 2")
Magazine capacity	150 - 300pcs	150 - 300pcs	200 - 300pcs	200 - 400pcs	200 - 400pcs
Operating pressure	1.28 - 2.26MPa (180 - 320PSI)	1.28 - 2.26MPa (180 - 320PSI)	0.98 - 2.26MPa (140 - 320PSI)	0.98 - 2.26MPa (140 - 320PSI)	0.98 - 2.26MPa (140 - 320PSI)
Dimensions (L x W x H)	293 x 125 x 319mm (11-1/2" x 4-7/8" x 12-1/2")	293 x 125 x 288mm (11-1/2" x 4-7/8" x 11-3/8")	282 x 136 x 277mm (11-1/8" x 5-3/8" x 10-7/8")	282 x 136 x 277mm (11-1/8" x 5-3/8" x 10-7/8")	260 x 136 x 255mm (10-1/4" x 5-3/8" x 10")
Net weight	2.3kg (5.1lbs)	2.1kg (4.6lbs)	1.8kg (4.0lbs)	1.9kg (4.2lbs)	1.3kg (2.9lbs)

Standard Equipment: Oil Supply, Safety Goggles, Nose Adapter, Floor Adapter (AN510H only), Board Adapter (AN510H only)

Pneumatic Roofing Coil Nailer AN450H

For nailing of asphalt and fiber glass shingles

Drives most popular roofing nails 19mm to 45mm (3/4" to 1-3/4")



Capacity	Length : 19 - 45mm (3/4" - 1-3/4")
Magazine capacity	120pcs
Operating pressure	1.28 - 2.26MPa (180 - 320PSI)
Dimensions (L x W x H)	287 x 117 x 276mm (11-1/4" x 4-5/8" x 10-7/8")
Net weight	2.2kg (4.8lbs)

4 Housing guards protects the machine from being damaged or scratched by mineral granules embedded in asphalt shingle.

Adjustable shingle guide enables to roof shingles in a straight row.



Standard Equipment: Oil Supply, Safety Goggles, Hex Wrench

All Tools do not come with nails.



Narrow Crown Stapler AT450H

for Furniture, Cabinet making, Interior trim



50mm staple can be firmly driven.

- Body bumper protects the workpiece from scratches / damages.
- Rubberized soft grip provides more control and comfort.
- Change lever for selecting the firing mode
- Exhaust port designed to direct exhaust air away from operator.
- Tool-less driving depth adjustment simply by turning a dial
- Hook can be turned.

Can drive up to 50mm staple



Makita original new technology!
Anti-buckle device ensure exact drive, even with a long staple.

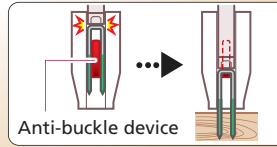

Anti-buckle device

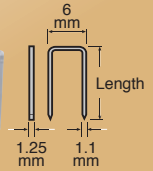

Capacity	Length : 25 - 50mm (1" - 2")
	Width : 6.35mm (1/4")
	Gauge : 18Ga
Magazine capacity	105pcs
Operating pressure	0.98 - 2.26MPa (140 - 320PSI)
Dimensions (L x W x H)	261 x 115 x 269mm (10-1/4" x 4-1/2" x 10-5/8")
Net weight	1.4kg (3.1lbs)

Standard Equipment: Oil Supply, Safety Goggles, Hex Wrench, Nose Cap

Pneumatic Pin Nailer AF500HP

for Furniture, Cabinet making, Interior trim, Dado rail, Window casing



Thick material is surely fastened perfectly with 50mm Pin nail.

- Ultra-fine finish by short stroke contact arm
- Body and magazine bumpers protect the workpiece from scratches / damages.
- Rubberized soft grip provides more control and comfort.
- Tool-less driving depth adjustment simply by turning a dial
- Hook attachable to either side

Excellent unremarkable finish



Predecessor model AF500HP

Thin nose exactly fits a narrow ditch.



0.6mm

Full scale 0.6mm



Capacity	Length: 15 - 50mm (5/8" - 2")
	Diameter : 0.6mm (1/32")
	Gauge : 23Ga
Magazine capacity	140pcs
Operating pressure	0.98 - 2.26MPa (140 - 320PSI)
Dimensions (L x W x H)	228 x 61 x 207mm (9" x 2-3/8" x 8-1/8")
Net weight	1.1kg (2.4lbs)

Standard Equipment: Oil Supply, Safety Goggles, Hex Wrench, Nose Adapter

Pneumatic Brad Nailer AF550H

for Furniture, Cabinet making, Paneling, Interior trim, Window casing



Thin nose exactly fits a narrow ditch.

- Ultra-fine finish by short stroke contact arm
- Body and magazine bumpers protect the workpiece from scratches / damages.
- Rubberized soft grip provides more control and comfort.
- Tool-less driving depth adjustment simply by turning a dial
- Hook attachable to either side

Excellent unremarkable finish

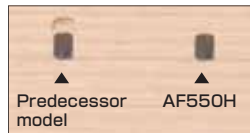

Predecessor model AF550H

Thin nose exactly fits a narrow ditch.



1.9mm

1.3mm



Capacity	Length: 15 - 55mm (5/8" - 2-3/16")
	Gauge : 18Ga
Magazine capacity	104pcs
Operating pressure	0.98 - 2.26MPa (140 - 320PSI)
Dimensions (L x W x H)	228 x 61 x 235mm (9" x 2-3/8" x 9-1/4")
Net weight	1.2kg (2.6lbs)

Standard Equipment: Oil Supply, Safety Goggles, Hex Wrench, Nose Adapter

All Tools do not come with nails.

Pneumatic Auto Feed Coil Screwdriver AR410HR

for Drywall to wood & steel



Certain driving with low noise

- Switcher driving mode can be selected according to the material of the workpiece.
- Contact top with rib easy to positioning for selectig driving mode
- Body bumper protects the workpiece from scratches / damages.
- Rubberized soft grip provides more control and comfort.
- Change lever for selecting the firing mode
- Tool-less driving depth adjustment simply by turning a dial
- Hook can be turned 360 degrees.

Strike and drive fastening system keeps original tightening strength.

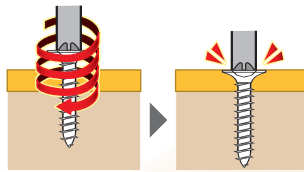

Can be fastening up to 0.8mm steel-made groundwork.

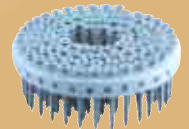
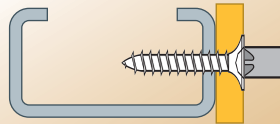

Standard Equipment: Oil Supply, Safety Goggles, Hex Wrench, Bit



Capacity	Length : 25 - 41mm (1" - 1-5/8")
	Diameter (Steel / Wood)
	: 3.5mm (1/8") / 3.8mm (5/32")
Magazine capacity	100pcs
Operating pressure	1.76 - 2.26MPa (260 - 320PSI)
Dimensions (L x W x H)	296 x 116 x 305mm (11-5/8" x 4-9/16" x 12")
Net weight	1.9kg (4.2lbs)

Pneumatic Impact Driver AD605H

for wide range of fastening applications



High pressure air + Soft impact = High speed driving

- Throttle lever with variable speed fanction
- Adjust handle tool speed can be set in 4 stages.
- Body bumper protects the workpiece from scratches / damages.
- Rubberized soft grip provides more control and comfort.
- Hook can be turned 180 degrees.

Bit sleeve with stable retention by using two steel balls



Can be fastened up to 150mm screw



Standard Equipment: Oil Supply, Hex Wrench

Tool does not come with bit.
All Tools do not come with nails.



Capacity	Length : 150mm (5-7/8")
	Diameter : 3.5 - 6mm (1/8" - 1/4")
Operating pressure	0.98 - 2.26MPa (140 - 320PSI)
No load speed (rpm)	0 - 10,000
Dimensions (L x W x H)	208 x 50 x 151mm (8-1/4" x 2" x 6")
Net weight	1.0kg (2.2lbs)

Optional Accessories



Air hose assembly
Part No.
30m : B-80020
15m : B-80014
7.5m : B-80036



Hose reel (30m)
Part No. B-80008



Carrying tool
Part No. HY00000212

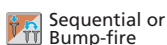



HIGH PRESSURE

Optional Accessories

Wire Coil Nails (Flat Type)



Dia	Length	Shank	Nails/ carton	Part No.
For Model: AN610H, AN620H, AN711H, AN911H				
2.5mm (0.099")	45mm (1-3/4")	Smooth	10,800	F-30810
		Screw Chisel	10,800	F-30865
	50mm (2")	Smooth	10,800	F-31243
		Screw Chisel	8,100	F-30878
	57mm (2-1/4")	Smooth	8,100	F-31256
		Screw Chisel	8,100	F-31269
2.8mm (0.110")	50mm (2")	Smooth	9,000	F-30823
		Smooth	9,000	F-30849

For Model: AN620H, AN711H, AN911H

Dia	Length	Shank	Nails/ carton	Part No.
2.9mm (0.113")	50mm (2")	Screw Chisel	9,000	F-30971
		Screw Chisel	6,750	F-31272
	57mm (2-1/4")	Screw Chisel	6,750	F-30881
3.1mm (0.120")		65mm (2-1/2")	Smooth	6,750
	3.3mm (0.131")		Smooth	4,050

For Model: AN711H, AN911H

Dia	Length	Shank	Nails/ carton	Part No.
2.9mm (0.113")	73mm (2-7/8")	Screw Chisel	6,750	F-31285
3.1mm (0.120")		Smooth	4,050	F-31298
3.2mm (0.120")	75mm (3")	Screw Chisel	4,050	F-31320
3.4mm (0.135")		Smooth	3,600	F-31359

For Model: AN911H

Dia	Length	Shank	Nails/ carton	Part No.
3.1mm (0.120")	85mm (3-1/4")	Smooth	4,050	F-31304
		Screw Chisel	4,050	F-31333
3.2mm (0.120")	90mm (3-1/2")	Smooth	4,050	F-31317
		Screw Chisel	4,050	F-31346
3.8mm (0.146")		Smooth	2,700	F-31362

Wire Coil Nails (Conical Type)



For Model: AN510H, AN610H • AN610H only

Dia	Length	Shank	Nails/ carton	Part No.
2.1mm (0.083")	32mm (1-1/4")	smooth	16,000	F-32766
		smooth		F-32779
	38mm (1-1/2")	screw		•F-32801
		smooth		F-32782
	45mm (1-3/4")	screw		•F-32814
		50mm (2")		smooth
screw	•F-32827			

Wire Coil Nails (Roofing Nail)

(7,200 pcs/box)



For Model: AN450H

Dia	Length	Shank	Part No.
3.1mm (0.120")	22mm (7/8")	Smooth	F-30762
	25mm (1")	Smooth	F-30775
	32mm (1-1/4")	Smooth	F-30788
	38mm (1-1/2")	Smooth	F-30791
	45mm (1-3/4")	Smooth	F-30807

Coil Tape Collated Screws

(2,000 pcs/box)

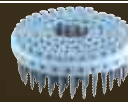

For Model: AR410HR

Dia	Length	Application	Part No.
3.5mm (0.139")	25mm (1")	Drywall to steel	F-32830
	28mm (1-1/8")		F-32843
	41mm (1-5/8")		F-32856
3.8mm (0.146")	25mm (1")	Drywall to wood	F-32869
	28mm (1-1/8")		F-32872
	32mm (1-1/4")		F-32885
	41mm (1-5/8")		F-32898

23Ga Pin Nail

(10,000 pcs/box)

• Stainless
For Model: AF500HP

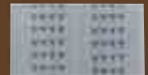

Length	Part No.
18mm (11/16")	F-31825
25mm (1")	F-31838
30mm (1-3/16")	F-31841
35mm (1-3/8")	F-31854
45mm (1-3/4")	F-32920
50mm (2")	F-32933
18mm (11/16")	• F-32142
25mm (1")	• F-32155
30mm (1-3/16")	• F-32168
35mm (1-3/8")	• F-32171

18Ga Brad Nail

(5,000 pcs/box)



For Model: AF550H

Length	Part No.
15mm (5/8")	F-31867
20mm (3/4")	F-31870
25mm (1")	F-31883
30mm (1-3/16")	F-31896
32mm (1-1/4")	F-31902
35mm (1-3/8")	F-31915
38mm (1-1/2")	F-31928
40mm (1-9/16")	F-31931
45mm (1-3/4")	F-31944
50mm (2")	F-31957
55mm (2-3/16")	F-32946

1/4" Narrow Crown

Floor Staple 18Ga

(5,040 pcs/box)



For Model: AT450H

Length	Part No.
25mm (1")	F-33517
32mm (1-1/4")	F-33520
38mm (1-1/2")	F-33533
45mm (1-3/4")	F-33546
50mm (2")	F-33559

Makita Corporation

3-11-8 Sumiyoshi-cho, Anjo, Aichi, 446-8502 Japan

PRINTED IN JAPAN Z15232-2 AJ-AD