

JET

J-350V

PORTABLE BANDSAW

J-350V..... 50000337M 1~230V, 50Hz

PARTS LIST

JPW (Tool) AG.

Tämperlistrasse 5
CH-8117 Fällanden
Switzerland

Phone +41 44 806 47 48

Fax +41 44 806 47 58

www.jettools.com

P-50000337M

2015-05

J-350V Bow saw breakdown

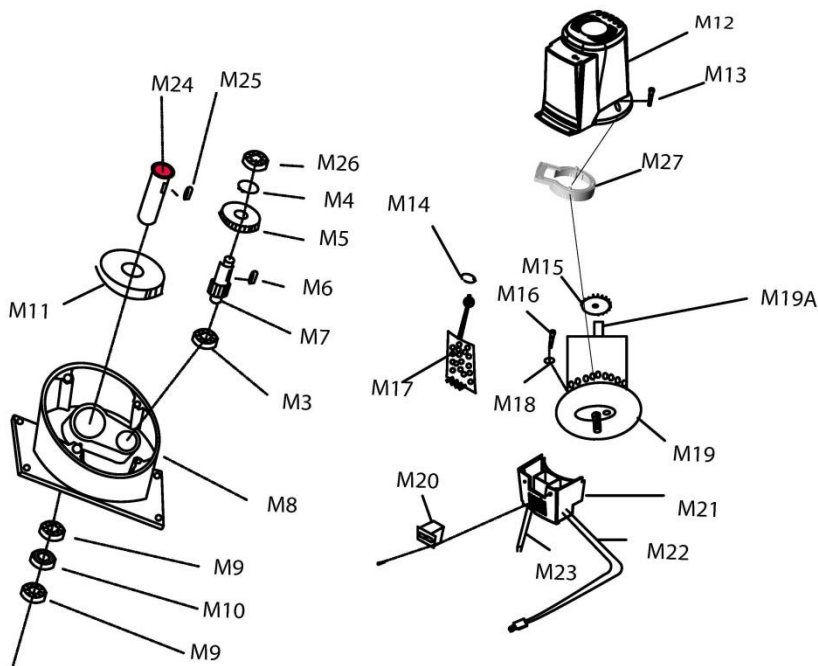
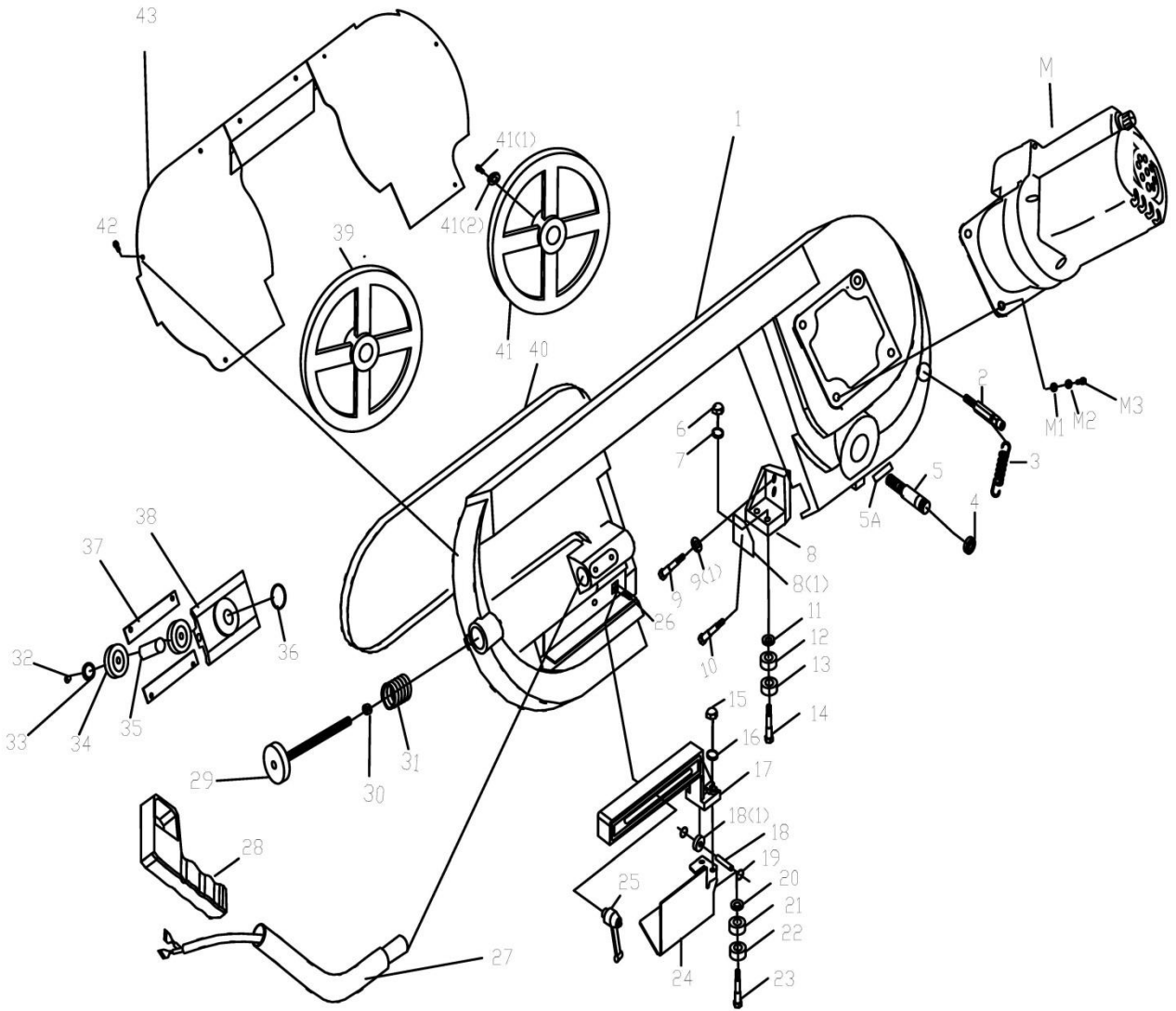

J-350V Bow saw Assembly

Index No.	Part No.	Description	Size	Q'ty
1	J-350V-01	Body Frame		1
2	J-350V-02	Spring Axis		1
3	J-350V-03	Spring		1
4	J-350V-04	Bearing	32004	1
5	J-350V-05	Axis		1
6	J-350V-06	Nut		2
7	J-350V-07	Washer		2
8	J-350V-08	Fixed Blade Guide Plate		1
8-1	J-350V-08-1	Chip Fence		1
9	J-350V-09	Screw		2
10	J-350V-10	Washer		2
11	J-350V-11	Washer		2
12	J-350V-12	Bearing		2
13	J-350V-13	Bearing		2
14	J-350V-14	Bias axis		2
15	J-350V-15	Nut		2
16	J-350V-16	Washer		2
17	J-350V-17	Arm		1
18	J-350V-18	Pin		2
18-1	J-350V-18-1	Bearing		2
19	J-350V-19	Washer		2
20	J-350V-20	Washer		2
21	J-350V-21	Bearing		2
22	J-350V-22	Bearing		2
23	J-350V-23	Bias axis		2
24	J-350V-24	L. Blade Guard		1
25	J-350V-25	Bolt		1
26	J-350V-26	Screw		1
27	J-350V-27	Handle Shelf		1
28	HS201402	Head Lever Handgrip		1
29	J-350V-29	Handle Wheel		1
30	J-350V-30	Washer		8
31	J-350V-31	Screw		2
32	J-350V-32	Screw		1
33	J-350V-33	Washer		1
34	J-350V-34	Bearing		2
35	J-350V-35	Blade sheet shaft		1
36	J-350V-36	Washer		1
37	J-350V-37	Block		2
38	J-350V-38	Block Blade Tension		1
39	J-350V-39	Return Flywheel		1
40	J-350V-40	Saw Blade		1
41	J-350V-41	Motor Flywheel		1
42	J-350V-42	Screw		6
43	J-350V-43	Body Cover		1
M	J-350V-M	Motor		1
M1	J-351V-M1	Screw		1
M2	J-351V-M2	Spring Washer		1
M3	J-351V-M3	Washer		1
M4	J-351V-M4	C-Ring		1
M5	J-351V-M5	Gear		1
M6	J-351V-M6	Key		1
M7	J-351V-M7	Gear Shaft		1
M8	J-351V-M8	Gear Box		1
M9	J-351V-M9	Bearing		2
M10	J-351V-M10	Oil Seal		1
M11	J-351V-M11	Gear		1
M12	J-351V-M12	UP Cover		1
M13	J-351V-M13	Screw	4x45 mm	1

Index No.	Part No.	Description	Size	Q'ty
M14	J-351V-M14	Nut		1
M15	J-351V-M15	Fan		1
M16	J-351V-M16	Screw		1
M17	J-351V-M17	Electrical Board		1
M18	J-351V-M18	Oil Seal		1
M19	J-351V-M19	Motor		1
M19A	J-351V-M19A	Motor Shaft		1
M20	J-351V-M20	Switch		1
M21	J-351V-M21	Down Cover		1
M22	J-351V-M22	Plug		1
M23	J-351V-M23	Handel Wire		1
M24	J-351V-M24	Main Shaft		1
M25	J-351V-M25	Key		1
M26	J-351V-M26	Bearing		1
M27	J-351V-M27	Middle Plastic Cover		1

J-350V Base breakdown

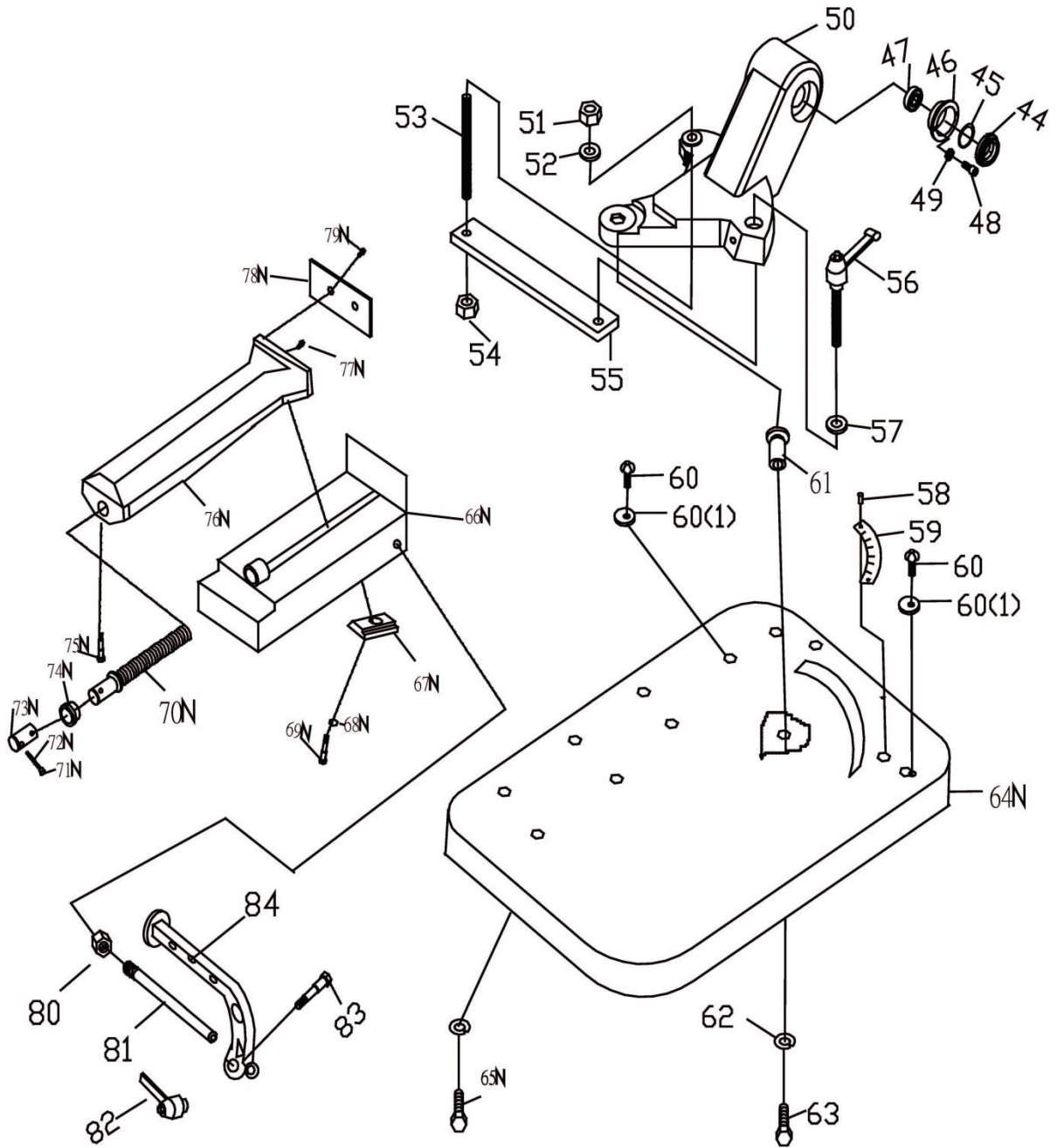

J-350V Base Assembly

Index No.	Part No.	Description	Size	Q'ty
44	J-350V-44	Nut		1
45	J-350V-45	Cover		1
46	J-350V-46	Bushing		1
47	J-350V-47	Bearing	32004	1
48	J-350V-48	Screw		1
49	J-350V-49	Washer		1
50	J-350V-50	Miter Plate		1
51	J-350V-51	Nut		1
52	J-350V-52	Washer		1
53	J-350V-53	Screw		1
54	J-350V-54	Nut		1
55	J-350V-55	Plate		1
56	J-350V-56	Bolt		1
57	J-350V-57	Washer		1
58	J-350V-58	Screw		1
59	J-350V-59	Scale		1
60	J-350V-60	Screw		1
60-1	J-350V-60-1	Washer		1
61	J-350V-61	Bushing		1
62	J-350V-62	Washer		1
63	J-350V-63	Screw		1
64N	J-350V-64N	Base		1
65N	J-350V-65N	Screw		1
66N	J-350V-66N	Fence Base		1
67N	J-350V-67N	Locking Seat		1
68N	J-350V-68N	Washer		1
69N	J-350V-69N	Screw		1
70N	J-350V-70N	Acme Screw		1
71N	J-350V-71N	Knob		1
72N	J-350V-72N	Handle Rod		1
73N	J-350V-73N	Shaft Bushing		1
74N	J-350V-74N	Bushing		1
75N	J-350V-75N	Screw		1
76N	J-350V-76N	Vise Cover		1
77N	J-350V-77N	Screw		1
78N	J-350V-78N	Vise Plate		1
79N	J-350V-79N	Screw		1
80	J-350V-80	Nut		1
81	J-350V-81	Rod Stock Stop		1
82	J-350V-82	Bolt		1
83	J-350V-83	Screw		1
84	J-350V-84	Stop Bracket		1

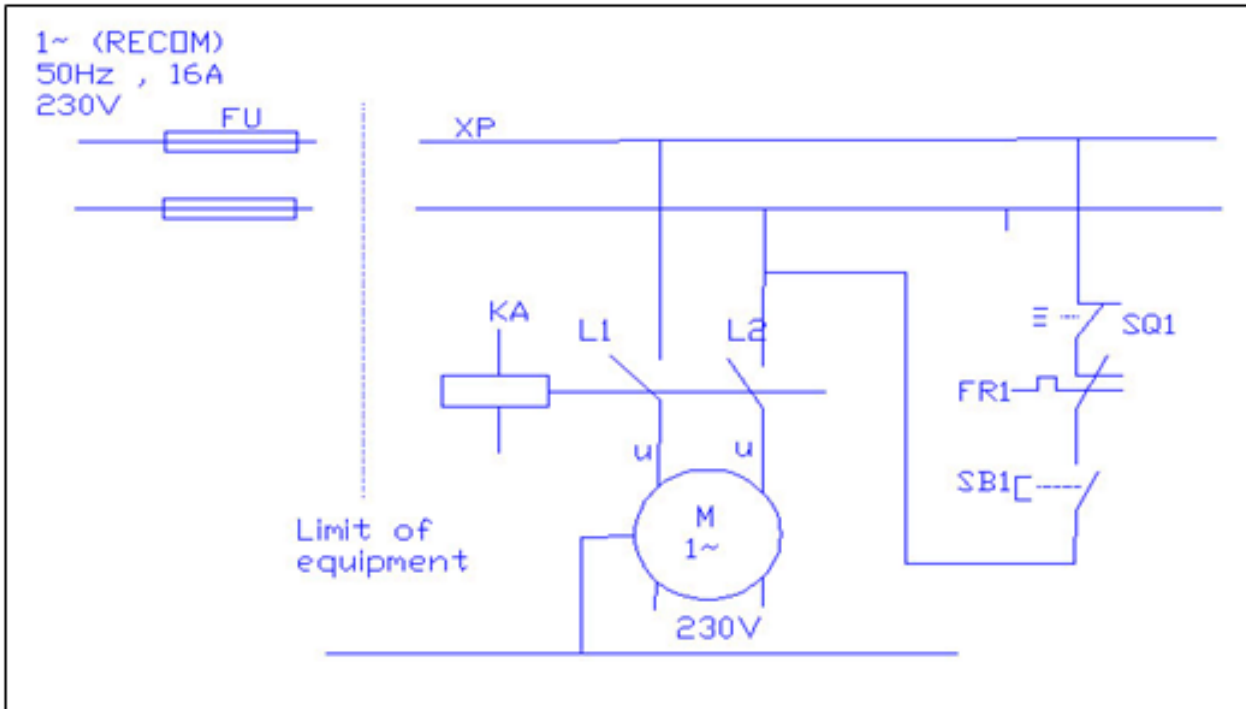

Item	Description	Description and function	Technical data
1	SB1	TR26-21C-13D/L SM-8 4P Switch with light	IP54:250Vac CE
2		Supply Cable	Ac 600V, 10A,3G/0.75mm
3	M	motor	2000W/230V,
4	SQ1	ZIPPY Micro Switch,VMN-15,15A	20.5A 125 / 250 Vac CE
5	FR1	Over Load	5A / 250 Vac CE